



Grip Chains: precise, corrosion-resistant, reliable!

Grip Chains from iwis have **wear- and corrosion-resistant** clamping elements that guarantee safe and reliable feeding, transport and positioning of thin-walled materials with a large surface area. Grip chains are used, for example, in **packaging, medical technology, electronics, PCB production** and **metalworking industry** applications.

iwis® Grip Chain Product Range

Gripping, feeding and conveying flexible films



Version A

With 1 tip



Version B

With 2 tips

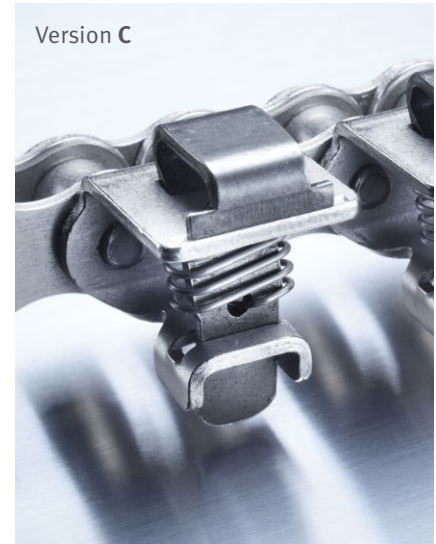

Version C

With flat clamps

Product highlights

- iwis high-performance chains with excellent wear resistance
- Minimal initial elongation due to optimum pre-stretching
- High rigidity also enables applications in long machines
- Basic chain versions are chemically nickel-plated / MEGAlife maintenance-free versions are available on request
- Identical chain lengths (within the selected tolerance range) ensure excellent running characteristics in both synchronous and parallel operation
- Differing levels of spring force allow an extremely wide range of materials to be gripped gently and held securely
- Chains with restricted length tolerances can be produced
- Recommended maximum running speed:
 - 2 m/s for the 1/2" grip chain
 - 0.6 m/s for the 5/8" grip chainDifferent control geometry is required for higher running speeds.
- iwis provides complete, ready-to-install solutions!

All chains can be supplied with a high-quality **food-grade** initial lubricant!





Version D

With button clamps



Version E

NEW

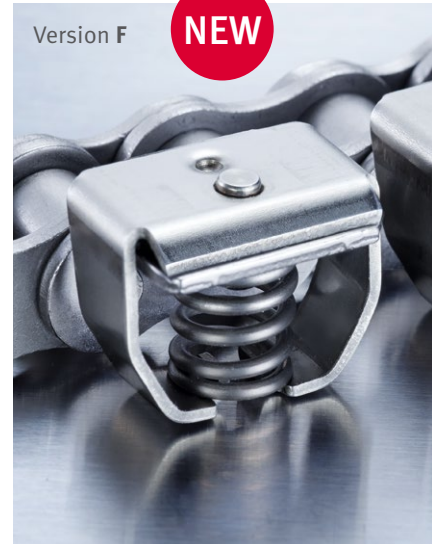

Version F

NEW

With clamp F

Our recommendation: the complete solution

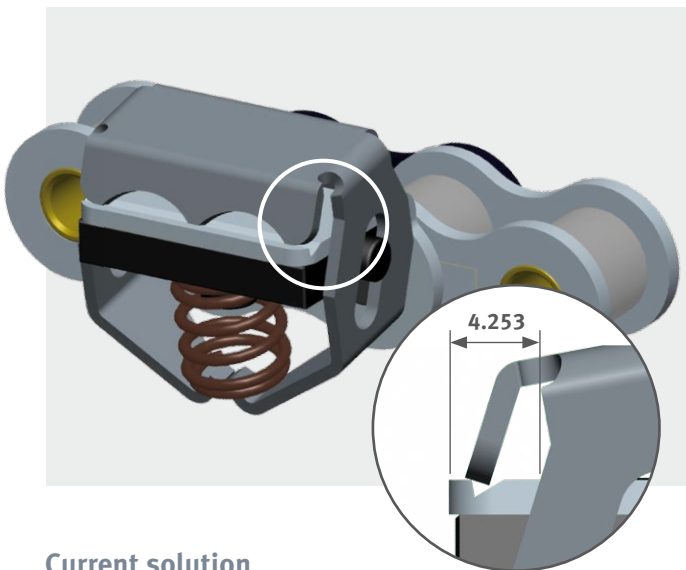

Current solution

- Not enough space to insert film
- Point load application to the film may cause film rupture and excessive noise emission
- Foil deformation possible at the edge of the gripper element

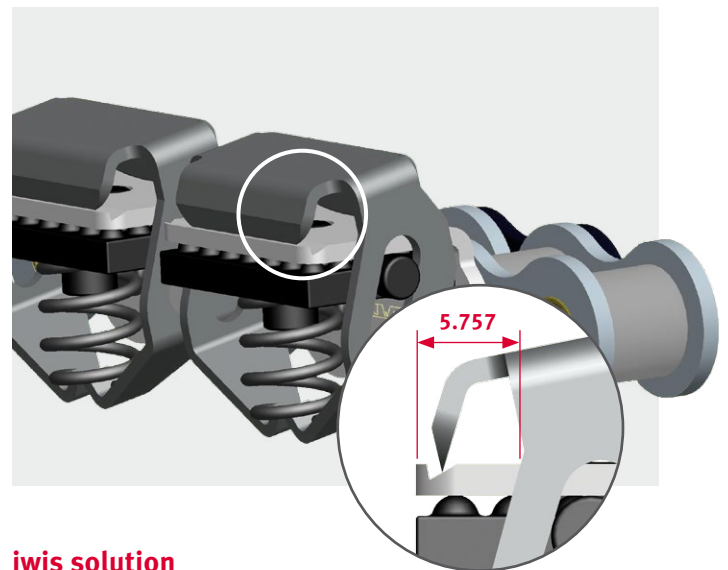

iwis solution

- Accurate fitting of gripper in the groove
- Better retention force than the competition
- Retention force dependent on plastic film used
- Burled plate for optimized functional safety and hygiene
- More free space for better foil insertion
- Films are not twisted, no deformation at the edge of the gripper element
- Lower noise emissions

Ahead of the competition!

“1-tip” Grip Chains



Technical features

- **Single and duplex chain** 1/2 x 5/16“ acc. to ISO 606
- Gripper with 1 tip, special designs on request
- Retention force is dependent on material conveyed and spring design – different number of coils and wire spring diameters available
- The gripper opens when it runs against a control disc (e.g. sprocket hub), causing it to swivel away outwards
- Food-grade initial lubrication
- Sprocket designs on request

Ref. no. iwis	DIN ISO	Pitch p (mm)	Ave. foil retention force (N) F^*	Spring	x	y	Mat. no.
L 85 Grip	08 B-1	12,7	10	0,7x6	5	6	50007495
L 85 Grip	08 B-1	12,7	24	0,9x5	4	5	50034722
D 85 Grip	08 B-2	12,7	10	0,7x6	5	6	50007033

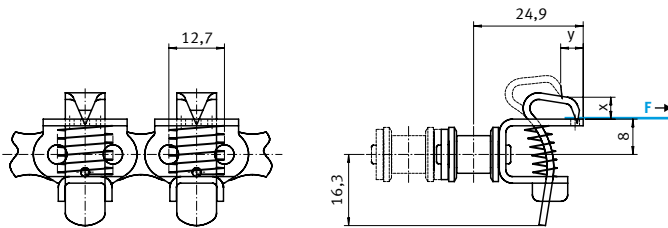

“2-tip” Grip Chains



Technical features

- **Single and duplex chain** 1/2 x 5/16“ acc. to ISO 606
- Gripper with 2 tips, special designs on request
- Retention force is dependent on material conveyed and spring design – different number of coils and wire spring diameters available
- The gripper opens when it runs against a control disc (e.g. sprocket hub), causing it to swivel away outwards
- Higher retention force in comparison with 1-tip grip chain
- Food-grade initial lubrication
- Sprocket designs on request

Ref. no. iwis	DIN ISO	Pitch p (mm)	Ave. foil retention force (N) F^*	x	y	Mat. no.
L 85 Grip	08 B-1	12,7	35	3,0	4,5	50024958

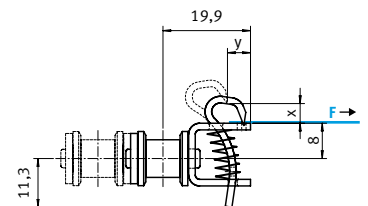

Dimensions x and y are dependent on the springs used. These are maximum values for the opening stroke. A smaller opening stroke will increase life expectancy of the spring.

* Reference films were used to determine the average film gripping force (F).

Concrete values are dependent on the film used (material, surface, thickness). Deviations are possible.

“Flat clamp” Grip Chains



Technical features

- **Single and duplex chain** 1/2 x 5/16“ acc. to ISO 606
- Gripper with flat clamping surface
- Retention force is dependent on material conveyed and spring design – different number of coils and wire spring diameters available
- The gripper opens when it runs against a control disc (e.g. sprocket hub), causing it to swivel away outwards
- Gentle handling of materials
- Low transmission forces
- Sprocket designs on request

Ref. no. iwis	DIN ISO	Pitch p (mm)	Ave. foil retention force (N) F*	Spring	x	y	Mat. no.
L 85 Grip	08 B-1	12,7	3	0,7x6	5	3,5	50037062
L 85 Grip	08 B-1	12,7	5	0,9x5	4	2,8	50035540

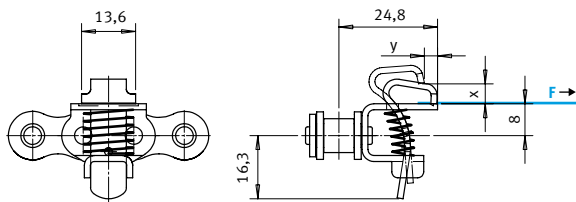

“Button clamp” Grip Chains



Technical features

- **Single chain** 1/2 x 5/16“ or 5/8 x 3/8“ acc. to ISO 606
- Rotationally symmetrical gripper element
- Extremely flat button clamp
- Retention force is dependent on material conveyed and spring design – different number of coils and wire spring diameters available
- **iwis patent** (spring without additional fixing elements)
- Does not swivel away outwards when opened
- Sprocket designs on request

Ref. no. iwis	DIN ISO	Pitch p (mm)	Ave. foil retention force (N) F*	e	Mat. no.
M 106	10 B-1	15,875	70	16,8	50034301
L 85	08 B-1	12,7	70	15,8	50035491

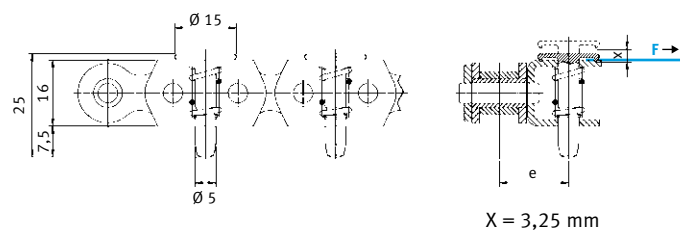

Dimensions x and y are dependent on the springs used. These are maximum values for the opening stroke. A smaller opening stroke will increase life expectancy of the spring.

* Reference films were used to determine the average film gripping force (F).

Concrete values are dependent on the film used (material, surface, thickness). Deviations are possible.

Version E – details of gripper function

Version E

NEW



Absolute precision!

- 1 Accurate fitting of gripper in the groove
- 2 Clamp made of corrosion-resistant, high-tensile, dimensionally stable steel
- 3 Burled plate guarantees optimum wear behaviour (steel-plastic)
- 4 Gripping flange with rounded sides to protect the conveyed plastic film
- 5 Sharp-edged, wear-resistant gripping flange guarantees long service life
- 6 “Support” radius on clamp for optimum opening and closing of the gripper (self centring)

Technical features

- Optimization of grip chain M106 with attachment 202.6 on one side and delivery as a complete solution with gripper system consisting of clamp, burled plate and spring
- Clamp and spring made of corrosion-resistant steel
- Chain is chemically nickel-plated
- Available with long-lasting lubrication or food-grade lubricant
- Alternative: M106 standard chain also available without attachments

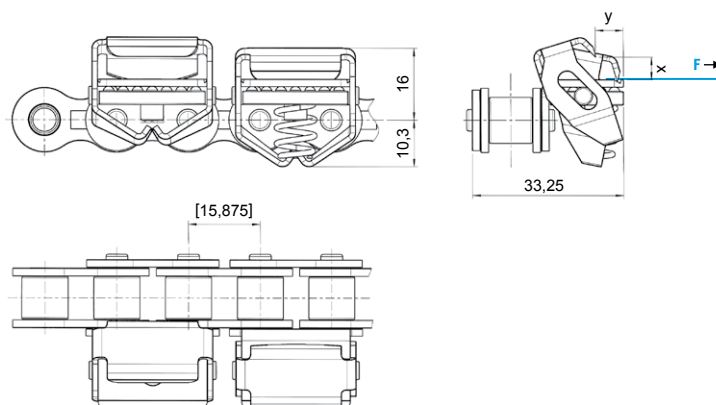

Ref. no. iwis	DIN ISO	Pitch p (mm)	Average foil retention force (N) F*	x	y	Mat. no.
M 106	10 B-1	15,875	85	4.9	6.1	50036920

Dimensions x and y are dependent on the springs used. These are maximum values for the opening stroke. A smaller opening stroke will increase life expectancy of the spring.

* Reference films were used to determine the average film gripping force (F).

Concrete values are dependent on the film used (material, surface, thickness). Deviations are possible.

Grip chain with clamp F



Control sprockets for Grip Chain applications

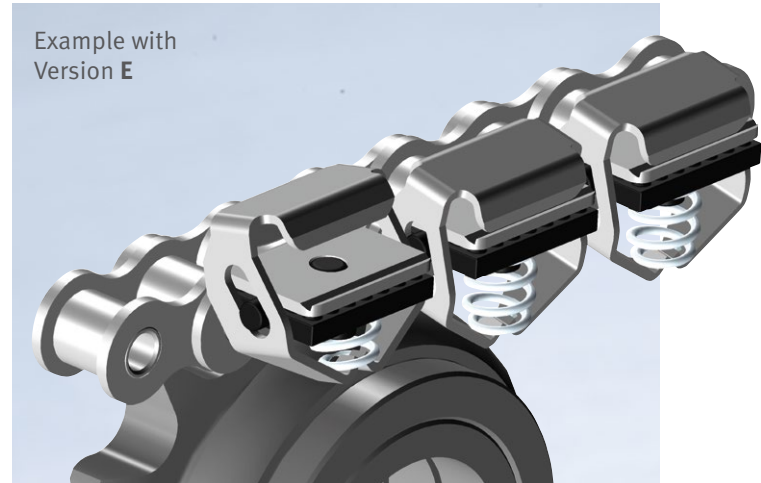

Technical features

- **Single and duplex chain** 1/2 x 5/16" acc. to ISO 606
- Complete gripper element
- Gripper element with a continuous sharp-aged gripping flange
- Retention force is dependent on material conveyed
- Clamp and spring made of stainless steel spring steel
- Due to a special geometry of sprockets used, the gripper opens with a slight sideways movement
- Food-grade initial lubrication
- Sprocket designs on request

Sprocket recommendations

- For applications with 1/2" **grip chains**, the recommended minimum number of teeth on the control sprocket is: **11**
- For applications with 5/8" **grip chains**, the recommended minimum number of teeth on the control sprocket is: **14**
- For improved running characteristics, we recommend control sprockets with a minimum of 19 teeth.
- We recommend the use of a ramp for sprockets with fewer than 20 teeth. A ramp is optional if sprockets have more than 20 teeth.
- Different spring sizes require different control disc diameters.

Customised designs

Sprockets can be supplied in accordance with customer specifications e.g. bearing seats, keyways, threads, special diameters, surfaces... Please advise us of the technical specifications and quantities you require.

Ref. no. iwis	DIN ISO	Pitch p (mm)	Average foil retention force (N) F*	Spring	x	y	Mat. no.
L 85 Grip	08 B-1	12,7	42	1,3x5,5	3	0,6	50045980

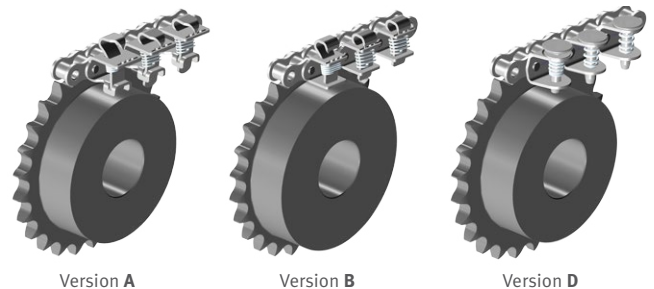
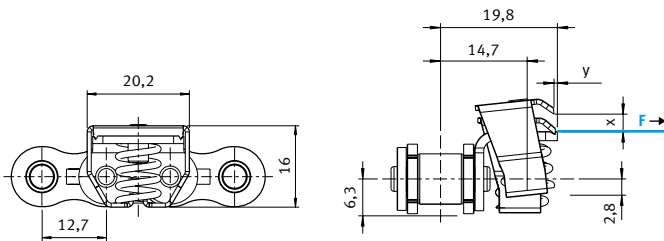

Dimensions x and y are dependent on the springs used. These are maximum values for the opening stroke. A smaller opening stroke will increase life expectancy of the spring.
 * Reference films were used to determine the average film gripping force (F).
 Concrete values are dependent on the film used (material, surface, thickness). Deviations are possible.

Our subsidiaries

Germany

iwis antriebssysteme GmbH & Co. KG
Albert-Roßhaupter-Straße 53
81369 München
Tel. +49 89 76909-1500
Fax +49 89 76909-1198
sales@iwis.com

Germany

iwis antriebssysteme GmbH
Essener Straße 23
57234 Wilnsdorf
Tel. +49 2739 86-0
Fax +49 2739 86-22
sales-wilnsdorf@iwis.com

Germany

iwis agrisystems
Schützenweg 5
36205 Sontra
Tel. +49 5653 9778-0
Fax +49 5653 9778-26
agrisystems@iwis.com

Great Britain

iwis drive systems Ltd.
Unit 8c Bloomfield Park
Bloomfield Road, Tipton
West Midlands, DY4 9AP
Tel. +44 12 15213600
Fax +44 12 15200822
salesuk@iwis.com

France

iwis systèmes de transmission
10, rue du Luxembourg
69330 Meyzieu
Tel. +33 4374515-70
Fax +33 4374515-71
salesfr@iwis.com

Switzerland

iwis AG Kettentechnik
Bahnweg 4 (Postfach)
5504 Othmarsingen
Tel. +41 62 8898999
Fax +41 62 8898990
info@iwis-ketten.ch

Italy

iwis antriebssysteme Italia
Tel. +39 340 9296142
Fax +49 89 7690949-1726
salesit@iwis.com

China

iwis drive systems (Suzhou) Co., Ltd.
No. 266 LvliangShan Road
215153 Suzhou SND
Tel. +86 512 8566-3020
Fax +86 512 8566-3009
salescn@iwis.com

USA

iwis drive systems, LLC
Building 100, 8266 Zionsville Road
Indianapolis, IN 46268
Tel. +1 317 821-3539
Fax +1 317 821-3569
sales@iwisusa.com

Canada

iwis drive systems, Inc.
101-19097, 26th Avenue,
Surrey BC V3Z 3V7
Tel. +1 604 560-6395
Fax +1 604 560-6397
salesca@iwisusa.com

Brazil

iwis Sistemas de Transmissão
de Energia Mecânica Ltda.
Rua Bento Rosa, nº 1816
Bairro Hidráulica
95.900-000 Lajeado, RS
Tel. +55 51 3748-7402
salesbrazil@iwis.com

South Africa

iwis drive systems, (Pty) Ltd
Unit 3, 127 Koornhof Road
Meadowdale, 1613
Tel. +27 11 392-2306
Fax +27 11 392-3295
salessa@iwis.com

Turkey

iwis tahrik sistemleri sanayi ve ticaret ltd.şti
Kağıthane Merkez Mah. Bağlar Cad. No: 14
Kağıthane Ofis Park 4C-Blok, TT04-FF2
34406 Kağıthane-İstanbul
Tel. +90-212-939 3843
Fax +90-212 939 3701
salestr@iwis.com

www.iwis.com

iwis
antriebssysteme
wir bewegen die welt

Your sales representative

